

PART NUMBER	MATERIAL
FTH-30-01	NYLON 6/6 UL 94 V-2 (RMS-01)

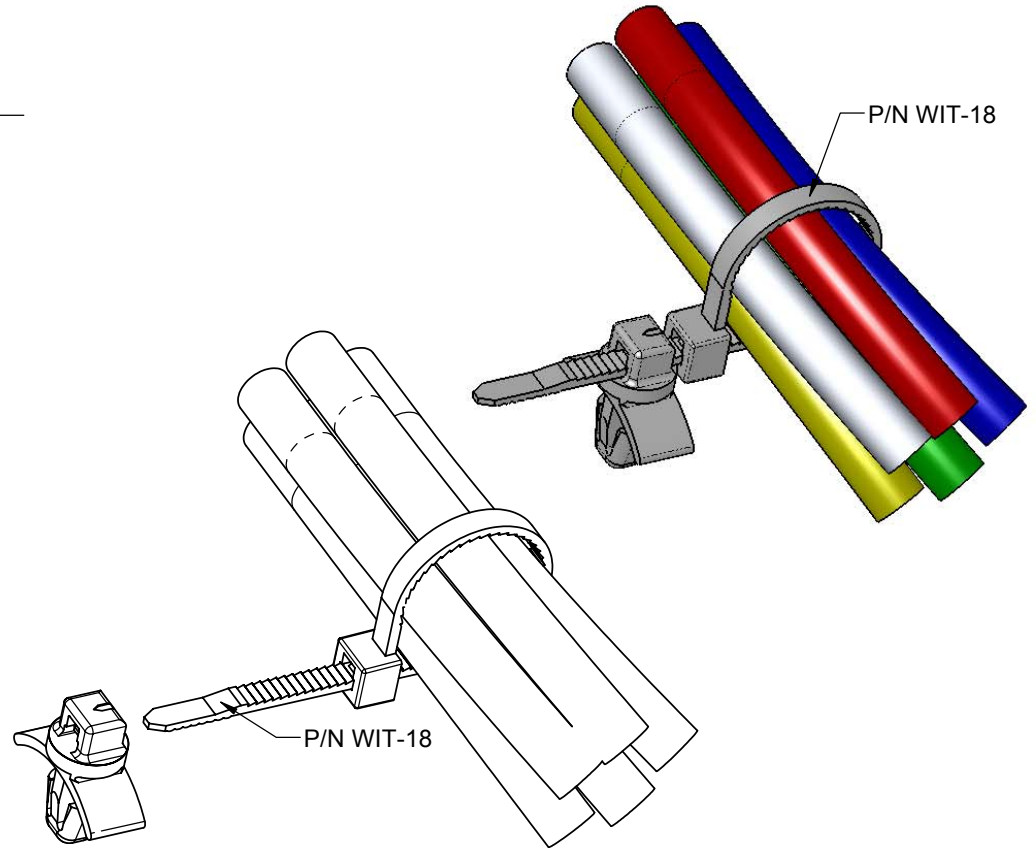
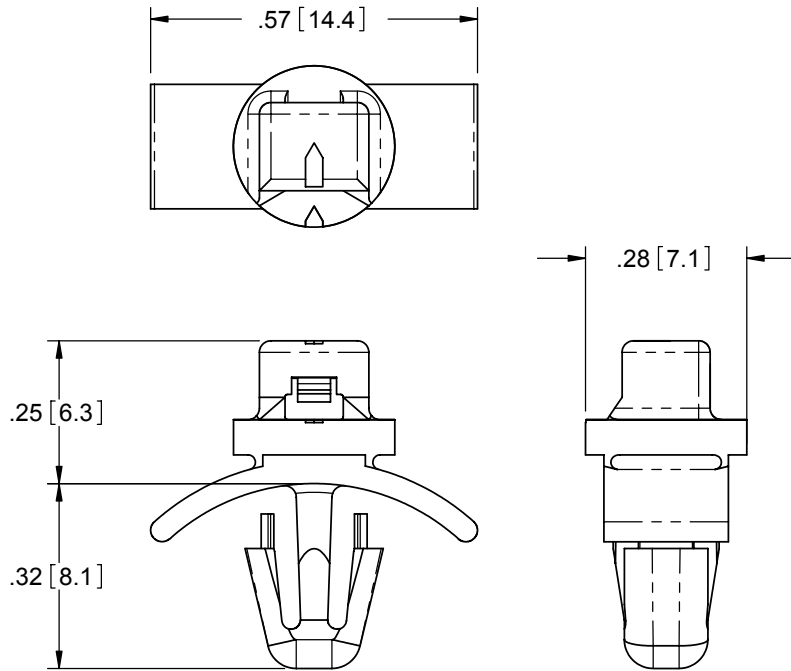

- NOTES:
1. MATERIAL: NYLON 6/6 UL 94 V-0 (RMS-19)
AVAILABLE BY SPECIAL ORDER ONLY.
TO ORDER REPLACE "-01" WITH "-19".
 2. COLOR: NATURAL.
 3. TO SNAP LOCK IN A $.187 \pm .003$ ($4.76 \pm .08$) DIAMETER HOLE
IN A $.031$ -. 078 THICK PANEL
 4. TO BE USED WITH RICHCO WIT-18 CABLE TIES, SOLD SEPERATELY
 5. ALTERNATE UNITS FOR REFERENCE ONLY

TITLE: HOOK MOUNT TIE HOLDER ON ARROWHEAD				DWG IN IN [MM]	FINAL	QR
CREATED USING SOLIDWORKS	FILE #: FTH-30	DWN: D.J.Z.	APP: D.J.Z.	FINAL		
TOLERANCES UNLESS NOTED XX=±.010 XXX=±.005 FRAC.=±1/64 ANG.=±1°	SHEET: 1 OF 1	SHEET SIZE: A	DT: 02/16/2006	CHKD: S.J.	PART #	PRINT TYPE
	RE: RICHCO INC. --	RICHCO, INC. ENG@RICHCO-INC.COM (773) 539-4060		SEE TABLE		CA

B	SEE ECN #1280 FOR CHANGES	S.K.	02/01/07
A	RELEASED FOR PRODUCTION	S.J.	2.16.06
REV.	DESCRIPTION	ENGR.	DATE